



NEW RELEASE BULLETIN

JANUARY 2019



Bendix are pleased to announce the addition of 6 new part numbers to the Protrans Commercial Vehicle Protrans Brake Linings Range.

Protrans brake linings are designed to perform whether you're on the highway, stop and starting, or on tough off-highway conditions. Offering reliability that performs on a range of commercial applications without compromising product life. Lining kits include all the rivets and the correct number of linings to reline the shoe cores.

Packed full of features, Protrans Brake Lining Kits offer:

- Premium Friction Material
- Ease of assembly during replacement
- Cost effective and durable

Friction Rating

Protrans linings are rated FF which means they maintain a high nominal friction level (0.35-0.45Mu) through the normal and high braking temperatures. The first letter of the code represents the "Normal" coefficient where temperatures range from 95°C–205°C. The second letter represents the "High" coefficient, with temperatures ranging from 150°C–350°C.

Applications:

Vehicle Make	Model	Variant	Brake System	Year of Manufacture	FRONT	REAR
MAN	HOCL	15.220	Fr.410 x 160mm Drum / Rr. 410 x 180mm Drum	1998 - On	MP/31/2	MP/32/2
MAN	HOCL	16.240	Fr.410 x 140mm Drum / Rr. 410 x 180mm Drum	1979 - On	MP/30/2	MP/32/2
MAN	HOCL	16.240	Fr.410 x 160mm Drum / Rr. 410 x 180mm Drum	1979 - On	MP/31/2	MP/32/2
MAN	HOCL	16.240	Fr.410 x 160mm Drum / Rr. 410 x 220mm Drum	1979 - On	MP/31/2	MP/36/2
MAN	HOCL	16.242	Fr.410 x 160mm Drum / Rr. 410 x 180mm Drum	1989 - On	MP/31/2	MP/32/2
MAN	HOCL	16.280	Fr.410 x 160mm Drum / Rr. 410 x 180mm Drum	1979 - On	MP/31/2	MP/32/2
MAN	HOCL	16.290	Fr.410 x 160mm Drum / Rr. 410 x 180mm Drum	1989 - On	MP/31/2	MP/32/2
MAN	HOCL	22.190	Rr. 410 x 220mm Drum		MP/36/2	
MAN	NL Series	NL 202	Fr.410 x 160mm Drum / Rr. 410 x 220mm Drum	1988.09 - On	MB/74/75/1	MB/76/77/1
MAN	NL Series	NL 262	Fr.410 x 160mm Drum / Rr. 410 x 220mm Drum	1991.04 - On	MB/74/75/1	MB/76/77/1
MAN	NL Series	NL 263	Fr.410 x 160mm Drum / Rr. 410 x 220mm Drum	1991.04 - On	MB/74/75/1	MB/76/77/1
MAN	O Series	O303	Fr. 410 x 160mm Drum / Rr. 410 x 160mm Drum	1987.09 - 1992.09	MB/74/75/1	MB/74/75/1
MAN	O Series	O303	Fr. 410 x 140mm Drum / Rr. 410 x 220mm Drum	1987.09 - 1992.09	MB/74/75/1	MB/76/77/1
MAN	O Series	O305	Fr. 410 x 140mm Drum / Rr. 410 x 220mm Drum	1978.10 - 1999.01	MB/74/75/1	MB/76/77/1
MAN	O Series	O405, N, NH, NH CNG	Fr. 410 x 140mm Drum / Rr. 410 x 220mm Drum	1988.02 - 1997.11	MB/74/75/1	MB/76/77/1
MAN	OF Series	OF1315	Fr. 410 x 160mm Drum / Rr. 410 x 180mm Drum	1992.01 - On	MP/31/2	MP/32/2
MAN	OF Series	OF1315	Fr. 410 x 140mm Drum / Rr. 410 x 180mm Drum	1988.08 - 1993.01	MP/30/2	MP/32/2
MAN	OH Series	OH1418	Fr. 410 x 160mm Drum / Rr. 410 x 160mm Drum	1990.03 - 1995.12	MP/31/2	MP/31/2
MAN	OH Series	OH1418	Fr. 410 x 160mm Drum / Rr. 410 x 180mm Drum	1996.01 - 2000.01	MP/31/2	MP/32/2
MAN	OH Series	OH1418	Fr. 410 x 140mm Drum / Rr. 410 x 180mm Drum	1996.01 - 2000.01	MP/30/2	MP/32/2
MAN	OH Series	OH1621, OH1621L	Fr. 410 x 160mm Drum / Rr. 410 x 220mm Drum	1997.05 - 2000.06	MP/31/2	MP/36/2
MAN	OH Series	OH1625	Fr. 410 x 160mm Drum / Rr. 410 x 220mm Drum	1990.10 - 1990.10	MP/31/2	MP/36/2
MAN	OH Series	OH1630	Fr. 410 x 160mm Drum / Rr. 410 x 220mm Drum	1990.10 - 1990.10	MP/31/2	MP/36/2
MAN	SL Series	SL 201	Fr. 410 x 160mm Drum / Rr. 410 x 220mm Drum	1984.04 - On	MB/74/75/1	MB/76/77/1
MAN	SL Series	SL 202	Fr. 410 x 160mm Drum / Rr. 410 x 220mm Drum	1984.04 - On	MB/74/75/1	MB/76/77/1
MAN	SG Series	SG 220 6x2	Fr. 410 x 160mm Drum / Rr. 410 x 220mm Drum	1976.07 - On	MP/31/2	MP/36/2
MAN	SG Series	SG240 Articulated	Fr.410 x 160mm Drum / Rr. 410 x 180mm Drum / Tr. 410 x 180mm Drum	1979 - On	MP/31/2	MP/32/2
MAN	SL Series	SL 200	Fr. 410 x 160mm Drum / Rr. 410 x 220mm Drum	1980.03 - On	MP/31/2	MP/36/2
MAN	SL Series	SL 202	Fr. 410 x 160mm Drum / Rr. 410 x 220mm Drum	1974.01 - On	MP/31/2	MP/36/2
MAN	SR Series	SR 280 6x2	Fr. 410 x 160mm Drum / Rr. 410 x 220mm Drum	1976.07 - On	MP/31/2	MP/36/2
Scania	3 Series	9.0 6-Cyl Diesel Bus [K93]	Fr. 410 x 178mm Drum / Rr. 410 x 178mm Drum	1991.01 - 1997.01	SV/40/2	SV/40/2
Scania	3 Series	11.0 6-Cyl Diesel Bus [K113]	Fr. 410 x 178mm Drum / Rr. 410 x 178mm Drum	1991.01 - 1997.01	SV/40/2	SV/40/2

Product Details:

Lining Kit#

MP/31/2

Specifications

- Length: 163
- No. Segments: 8
- Rivets per Kit: 64

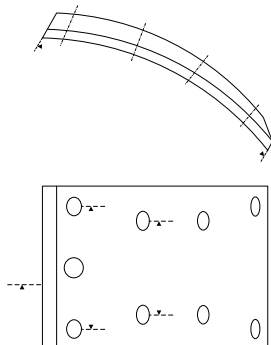

Lining Kit#

MP/32/2

Specifications

- Length: 183
- No. Segments: 8
- Rivets per Kit: 64

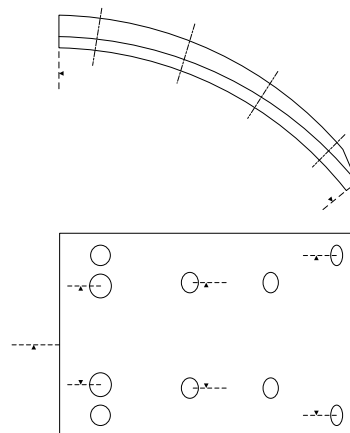

Lining Kit#

MP/36/2

Specifications

- Length: 223
- No. Segments: 8
- Rivets per Kit: 64

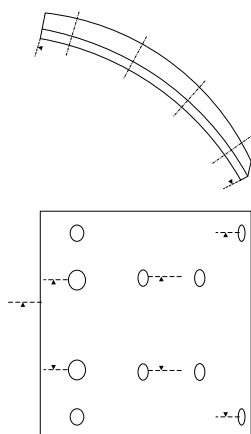

Lining Kit#

MB/74/75/2

Specifications

- Length: 163
- No. Segments: 8
- Rivets per Kit: 72

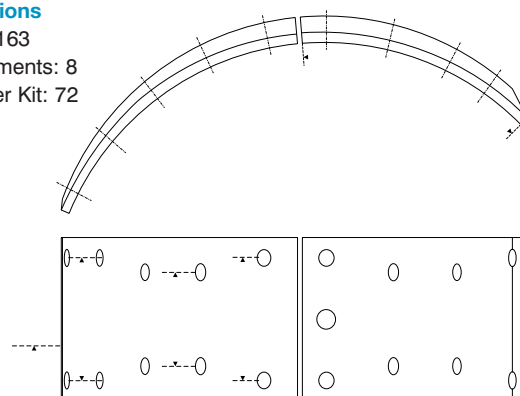

Lining Kit#

MB/76/77/2

Specifications

- Length: 222
- No. Segments: 8
- Rivets per Kit: 72

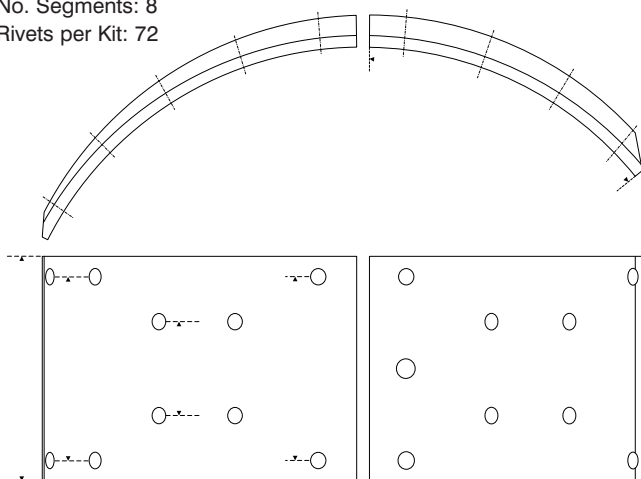

Lining Kit#

SV/40/2

Specifications

- Length: 178
- No. Segments: 8
- Rivets per Kit: 128

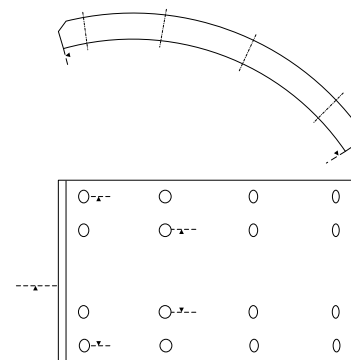

For further details please contact the Bendix Brake Advice Centre on **1800 819 666**, 8am to 5pm, Monday to Friday, or your local Bendix representative.

Pending initial demand for this reference, we will be endeavoring to fill all orders within the normal delivery time, however, should orders exceed the expected demand, stock will be allocated in priority of received order date.

Also available from Bendix is the Ancillary Solutions range which is designed to complement the Commercial Vehicle products, offering you all you need to complete the perfect brake change.



CERAMASIL BRAKE PARTS LUBRICANT

Specially formulated from pure synthetic base oils and treated with the latest rust, oxidation and anti-wear additives to provide lasting protection against friction, wear and corrosion.



BRAKE CLEANER & PARTS DEGREASER

A full strength cleaner and degreaser that safely and effectively removes brake fluid, grease, oil and other contaminants from brake and parts components. It can dissolve grease and grime without brake disassembly.

PRODUCT	500mL
Part No.	BBL20
Weight	255g
Barcode	9316068403174

PRODUCT	Aerosol	Trade Drum	Pump Spray
Part No.	BBC4	BBC20	BBC1L-PUMP
Weight	400g	20L	1L
Barcode	9316068186053	9316068193686	9316068403655



FOR MORE INFORMATION
 Freecall the Bendix Brake Advice Centre on
 1800 819 666 (8am-5pm Monday to Friday EST)
 or +61 3 5327 0211 from overseas.
brakeadvicecentre@bendix.com.au
bendix.com.au or bendix.co.nz



*Bendix brake components are appropriate for the purpose intended and if installed by qualified staff, to the vehicle manufacturer's specifications, can be used in logbook servicing.

Put your foot down with confidence™

